

PAVE DRAIN

STORMWATER'S ARCH ENEMY

Sustainable Stormwater Solutions



Structural and Environmental Benefits

The PaveDrain® System combines modern day functionality and a structural concept used for centuries to create *the* revolutionary permeable paving solution. PaveDrain incorporates a patented arch design in the middle of an articulating concrete block to create an internal storage chamber that can be filled with stormwater runoff while simultaneously providing strength for heavy vehicular loads. The PaveDrain System is designed to be a critical component of Low Impact Development (LID) allowing for the infiltration of stormwater runoff...onsite.

The PaveDrain System is a Permeable Articulating Concrete Block/Mat (P-ACB/M)¹ that provides environmental benefits as a designated solution for compliance with local regulatory stormwater requirements. The durability and performance, in terms of life-cycle costs, make it the prudent alternative to all other paving surfaces. PaveDrain and its aggregate bedding stone is engineered to create a natural, vertical infiltration path, that recharges local groundwater all while using nature's inherent ability to filter first flush pollutants. This allows for a reduction or elimination in stormwater infrastructure while minimizing the environmental impact. In addition to effectively managing stormwater runoff the PaveDrain System is also being developed using recycled materials which will make it one of the leading green technologies for stormwater management. PaveDrain works.

¹ Permeable Articulating Concrete Block/Mat & P-ACB/M are Registered Trademarks of ECS Solutions, LLC.

ASTM Standards & ADA Compliance

The PaveDrain System meets the requirements of ASTM D6684-04 and is recognized by the USEPA as a structural Best Management Practice (BMP) for stormwater infiltration. The Americans with Disabilities Act (ADA) Design Guidelines require that surface openings shall not exceed 1/2" and shall be firm, stable, and slip resistant. The PaveDrain System easily exceeds all these requirements by incorporating a 3/8" gap between individual PaveDrain blocks.

Applications

- Parking Lots
- Alley Ways
- Low Speed Roadways
- Intersections
- Emergency Access Lanes
- Residential Driveways

Why the PaveDrain System?

As part of the Clean Water Act, the EPA developed the National Pollution Discharge Elimination System (NPDES) to improve water quality by regulating point sources that discharge pollutants into waters of the U.S. The vast majority of storm water drainage systems are considered to be point sources.



Infiltration Report

The PaveDrain System® was tested and documented by American Excelsior Company's ErosionLab® to help better understand its infiltration capabilities. It was installed over two plots that contained an identical six inch aggregate bedding layer, but different underlying soils consisting of clay and sand. The plots were exposed to increasing simulated one hour duration rainfall events (i.e. 4", 6" and 8") until runoff was measured. View the entire ErosionLab report by visiting our website at www.pavedrain.com and go to *How it Works*.

PaveDrain System Properties

Thickness 5.65" (+ 1/8")
Unit Dimensions 11.75" x 11.75"
Unit Weight 42-45 lbs
Units/SF 1 SF Nominal
Percentage Open Space: 3% Surface, 20% Storage Area



Bladensburg, Maryland demonstration tests

Installation Diagram

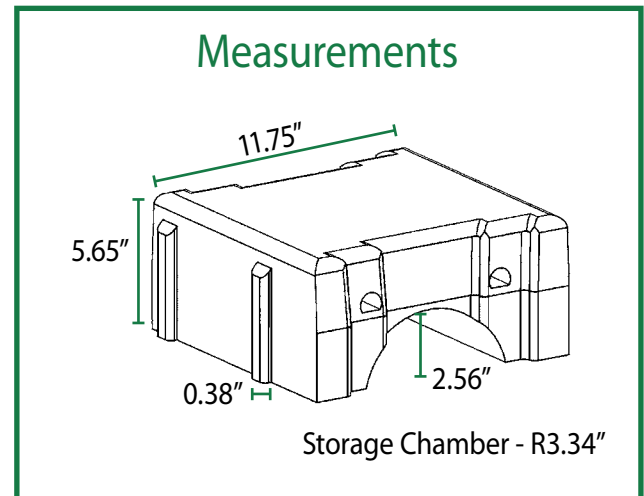
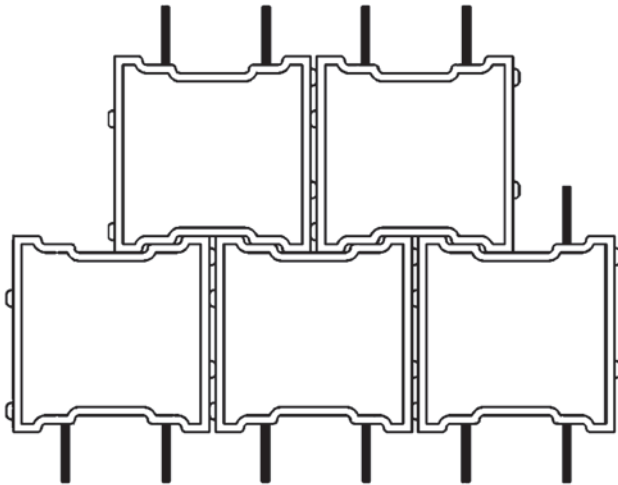

PaveDrain System Blocks End View Cross Section

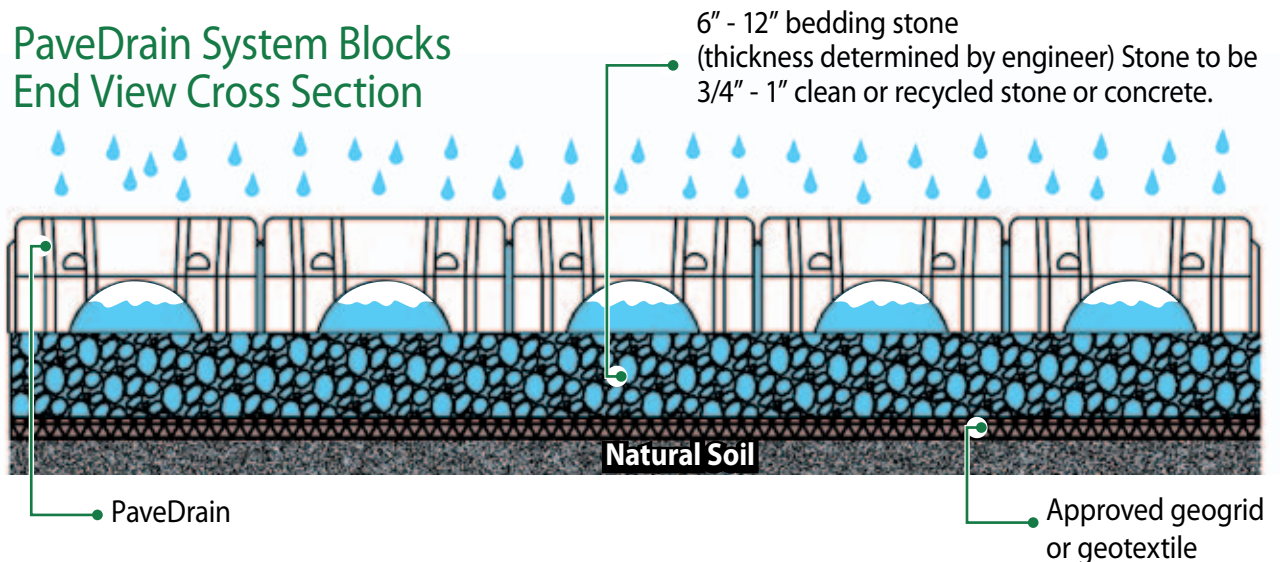

LEED Credits: Sustainable Sites

- **CREDIT 6.1**

Stormwater Design, Rate & Quality Control: 1 Point
Limit distribution of natural water flows by managing stormwater runoff.

- **CREDIT 6.2**

Stormwater Treatment: 1 Point
Implement a stormwater management plan that reduces impervious cover, promotes on-site filtration and eliminates contaminants.

- **CREDIT 5.1**

Site Development: 1 Point
Protect or restore habitat

- **CREDIT 7.1**

Heat Island Effect, Non Roof: 1 Point
Reduce heat islands

MATERIALS & RESOURCES:

- **CREDIT 5.2** Regional Materials: 1 Point

Maintenance and Repair

The PaveDrain System is easy to maintain using industrial vacuuming equipment, if needed. If a significant amount of sediment accumulates in the aggregate bedding stone, PaveDrain is the only system that can be mechanically lifted out allowing for the subgrade to be cleaned and then the same mats re-installed. Repair of individual PaveDrain blocks can be accomplished without removing the (mat) cables. For more detailed information on these topics go to www.pavedrain.com and select **Installation Guidelines** and then click on *repair*.

Additional Benefits

- Initial installations show a drastic reduction in the use of deicing salts over traditional asphalt and concrete surfaces.
- Installed with conventional construction equipment
- Available in several color options
- Fast, economical installation of intersection construction or retrofits of existing pavements
- No seams to catch on snow plows
- Available in multiple mat sizes for customized applications
- Regional manufacturing supporting local economies
- Adaptable to small areas where retention ponds are not practical

Represented Locally By;

Tel: (787)-754-1657
info@viatekpr.com
www.viatekpr.com



PaveDrain, LLC

PMB 292

7245 S. 76th Street, Franklin, WI 53132-9041

(414) 423-6531 Office

www.pavedrain.com

©2011 PaveDrain, LLC All Rights Reserved.

PaveDrain System is a registered trademark of PaveDrain, LLC

